

IN-032-05



Electronic PinBrazing unit



USER MANUAL

Safety, Operation and Maintenance

SAFETY SYMBOLS

Safety symbols and signal words, as shown below, are used to emphasize all operator, maintenance and repair actions which, if not strictly followed, could result in a life-threatening situation, bodily injury or damage to equipment.



This is the safety alert symbol. It is used to alert you to potential personal injury hazards. Obey all safety messages that follow this symbol to avoid possible injury or death.



This safety alert and signal word indicate an imminently hazardous situation which, if not avoided, will result in death or serious injury.



This safety alert and signal word indicate a potentially hazardous situation which, if not avoided, could result in death or serious injury.



This safety alert and signal word indicate a potentially hazardous situation which, if not avoided, could result in death or serious injury.



This signal word indicates a potentially hazardous situation which, if not avoided, may result in property damage.



This signal word indicates a situation which, if not avoided, will result in damage to the equipment.



This signal word indicates a situation which, if not avoided, may result in damage to the equipment.

Always observe safety symbols. They are included for your safety and for the protection of the tool.

LOCAL SAFETY REGULATIONS

Enter any local safety regulations here. Keep these instructions in an area accessible to the operator and maintenance personnel.

Tool operators and maintenance personnel must always comply with the safety precautions given in this manual and on the stickers and tags attached to the tool and hose.

These safety precautions are given for your safety. Review them carefully before operating the tool and before performing general maintenance or repairs. Supervising personnel should develop additional precautions relating to the specific work area and local safety regulations. If so, place the added precautions in the space provided in this manual. This tool will provide safe and dependable service if operated in accordance with the instructions given in this manual. Read and understand this manual and any stickers and tags attached to the tool before operation. Failure to do so could result in personal injury or equipment damage.

- Do not operate a damaged, improperly adjusted, or incompletely assembled tools.
- To avoid personal injury or equipment damage, all tool repair, maintenance and service must only be performed by authorized and properly trained personnel.
- Do not exceed the rated limits of the tool or use the tool for applications beyond its design capacity.
- Always keep critical tool markings, such as labels and warning stickers legible.
- Always replace parts with replacement parts recommended by Safetrack.



- Operator must start in a work area without bystanders. The operator must be familiar with all prohibited work areas such as excessive slopes, dangerous terrain conditions, and rail traffic.
- Establish a training program for all operators to ensure safe operation.
- Do not operate the tool unless thoroughly trained or under the supervision of an instructor.
- Always wear safety equipment such as goggles, ear, head protection, and respiratory protection at all times when operating the tool.
- Do not inspect or clean the tool while the battery power source is connected. Accidental arcing can cause serious injury.
- Do not load brazing pins or ceramic rings while the battery power source is connected. Accidental arcing can cause serious injury.
- Do not use the tool while it is connected to a battery charger.
- Ensure battery charging is only done in a dry environment. Charging batteries in the rain or near standing water presents an electrocution hazard. Read the safety and operation instructions provided with the battery charger before using the battery charger.

TABLE OF CONTENTS

SAFETY SYMBOLS	2
SAFETY PRECAUTIONS	3
TABLE OF CONTENTS	4
TECHNICAL SPECIFICATION	5
PROTECTION/CLEANING/STORAGE	6-7
OPERATION	8-11
BATTERY CHARGING	8
GRINDING	9
PREPARING THE ECONECT UNIT	10
PINBRAZING	11
TROUBLESHOOTING	12
MAINTENANCE	13-15
GENERAL MAINTENANCE	13
ECONECT SPECIAL FUNCTIONS	14
S15 BRAZING GUN	15
CHECKING/CALIBRATING LIFT HEIGHT	16-17
ACCESSORIES & SPARE PARTS	18
REPAIRS/RETURNS	19
NOTEPAD	20
CE DECLARATION OF CONFORMITY	21

IMPORTANT

**Read the instructions carefully
before using the pinbrazing unit.**



WARRANTY

Units 12 months, batteries 6 months.

Valid only when using original parts, batteries and chargers supplied or approved by Safetrack®. The warranty will expire if the equipment was used or has been used with non-original spare parts, consumables or not used in accordance with the instructions.

Website: www.safetrack.se

E-Mail: sales@safetrack.se

⚠ WARNING

**SERIOUS INJURY OR DEATH COULD RESULT FROM
THE IMPROPER REPAIR OR SERVICE OF THIS TOOL.**

**REPAIRS AND / OR SERVICE TO THIS TOOL MUST ONLY BE DONE
BY AN AUTHORIZED AND CERTIFIED DEALER.**

SAFE 94365 DELIVERED WITH

ECONNECT	SAFE 94451
S15 Gun	SAFE 91015
Tool kit	SAFE 91250
Ground device	SAFE 80730
Charger	SAFE 8048
Tool case	SAFE 95240
Carrying Harness	SAFE 9523
Protective eyewear	SAFE 8043
Grinding pin/stone	SAFE 8025
Carbide burr	SAFE 8014

**Check that all parts
have been received!**

TECHNICAL SPECIFICATION

Voltage	39V DC
No. of brazings/charge	40-60
Unit weight incl.batteries	9,8 Kg
Dimensions LxWxH (mm)	321x153x280
Temperature range	-20 °C to +55 °C



GENERAL PROTECTION

Use only recommended repair and replacement parts and materials specified in the spareparts list section of this manual.

Use only recommended accessories also specified in the spareparts list section of this manual.

Do not use the Electronic PinBrazing unit for applications it was not designed for.
Use the carrying handle to transport the unit from location to location.

CLEANING

Establish a routine to keep the unit as free from dirt as possible: –daily, or at each shift change, for example.

PinBrazing unit exposed to rain, sand, or grit-laden air should be cleaned prior to each use.
Keep tool labels and stickers legible.

PREOPERATION PROCEDURES

Before putting a new ECONECT PinBrazing unit into initial service, or after an extended period of being unused, perform a visual inspection for bent, broken, cracked, missing or worn components.

STORAGE OF UNIT AND BATTERIES

Store the Electronic PinBrazing unit in a place where it is protected from the elements, abrasive dust, and damage.

The batteries must be stored in a clean and dry location, and preferably in a temperature-controlled environment.

Units are shipped with the batteries not fully charged. Please charge the unit before use.

The batteries must be given a freshening charge once every year if the unit is not in use.

Failure to observe these conditions may result in greatly reduced capacity and service life.

! WARNING

Only charge the unit indoors at room temperature.

Failure to follow the instructions in the battery charger operation manual can result in battery explosion and serious bodily injury. To reduce the risk of battery explosion, read and understand the safety and operation instructions in the battery charger operation manual, the instructions published by the battery manufacturer, and the instructions in this manual before attempting to charge the batteries.

NOTICE

Use only battery charger specially made for PinBrazing unit ECONECT (36V DC) approved by Safetrack.

CHARGING THE BATTERY

NOTICE

CHARGING THE BATTERY CAN ONLY BE CARRIED OUT BETWEEN 0°C to +45°C

CAUTION

If the batteries are left uncharged, they may be damaged.

Connect the charger to the grinder / charging outlet on the unit then to the mains.
The battery is fully charged after about 1 hour (if completely discharged).
After charging is completed the charger can be disconnected.
The battery shall be charged every 6 months, if the unit is not in use.

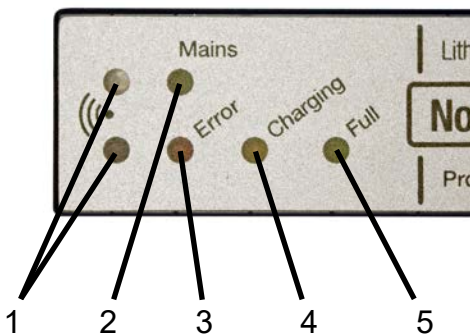

1. Infrared-LED, For factory programming only.
2. Mains, indicating that mains are connected and the charger is on.
3. Red Error-LED, indicating different errors by flashing, see chart 1.
4. Yellow Charging-LED, indicating when the charger is charging the battery.
5. Green Full-LED, indicating when battery is fully charged.

Chart 1.

Blinking signal*	Error description	Troubleshooting
1 x Blinking, 2 sec pause	No battery or defect battery.	Please check charger cable and connector for damage and the 15A fuse on Econect.
2 x Blinking, 2 sec pause	Battery voltage is too high.	
3 x Blinking, 2 sec pause	Battery temperature is under 0°C or over 45°C.	Please let the unit cool or heat to the right temperature, charging will start automatically.
5 x Blinking, 2 sec pause	Device temperature is too high.	Please turn off the charger and give it some time to cool down.

* Blinking signals in continuous loop.



Always use eye protection when grinding and brazing.

NOTICE

Note, use only Safetrack grinding wheel specially made for brazing. Other type of wheels will leave a surface not suitable for brazing. Keep the grinding wheel clean and free from oil etc.

Before brazing, the braze area must be cleaned of rust, corrosion, paint, pits, or other contamination at the points where the brazing is going to be done and on an area close to the brazing for placement of the grounding cable.

Cleaning is accomplished with a grinder to ensure clean, bare metal.

Connect the grinder. If unit was supplied with battery power grinder, make sure that the batteries are charged. See manufactures instruction for the grinder on charging the grinder batteries.



1. Grind the brazing and ground area until you have an even and clean surface.

2. Attach the ground magnet on the same work piece where the pinbrazing should be done. Try to attach the magnet within 0,5m from brazing area.

3. Move the grinder all time when grinding to get an even surface.

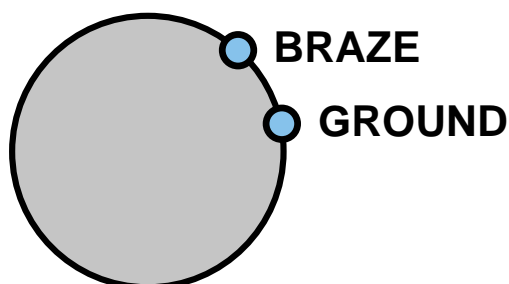

NOTICE

If the temperature of the battery is below 12°C, the ERROR will flash and the battery will be heated.
When battery has right temperature ERROR will stop flashing and unit is ready to use.

Heating time and number of brazings

The build-in heating element automatically heat up the batteries. (Heating time)
Possible amount of brazings (see specified brazing pin)

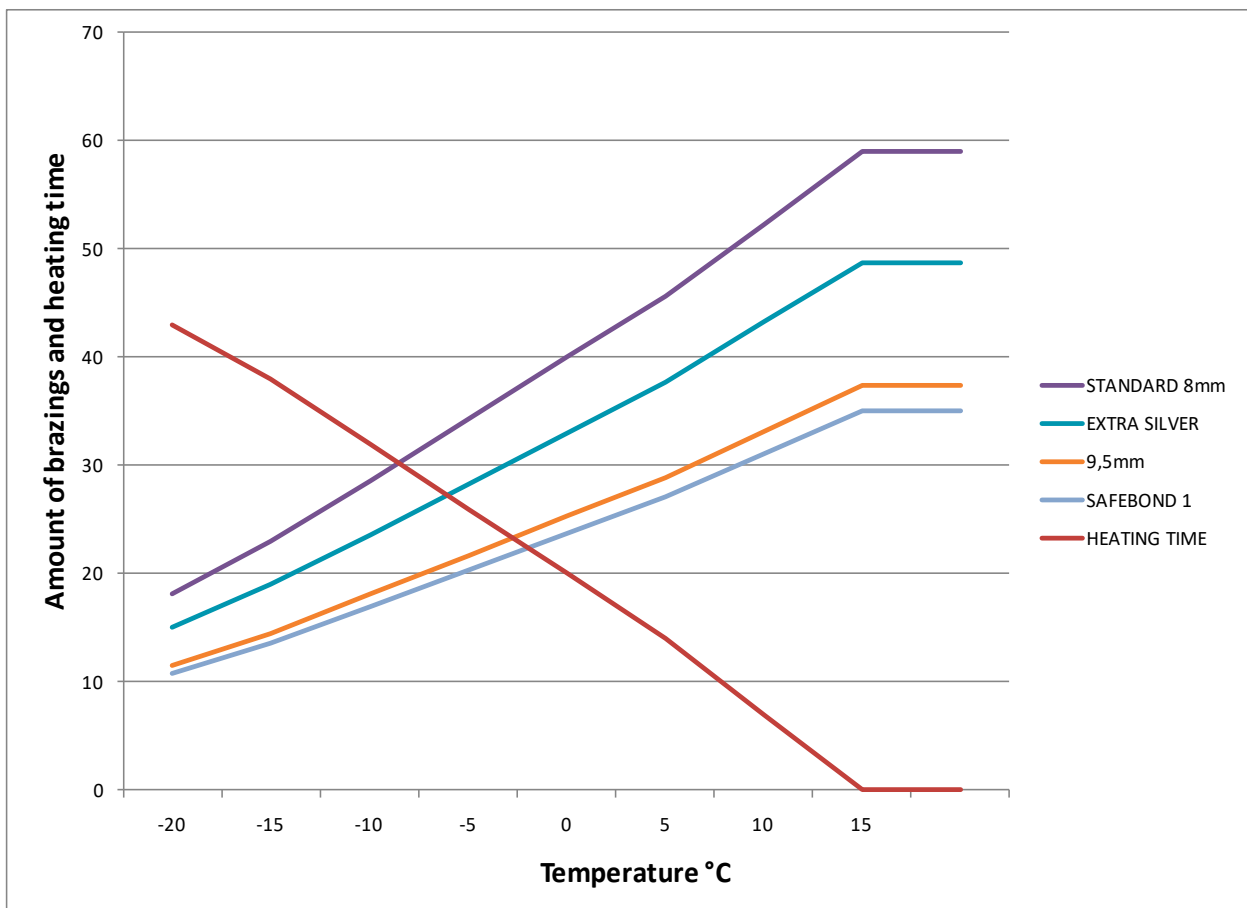

1. Connect the brazing gun cables (power and trigger) & ground device to the unit.
2. Select brazing pins and ceramic rings to match the specifications of the bonding cable you selected.
3. Check that the pin holder and ring holder on the gun are the correct sizes for the brazing pins and ceramic rings you selected. If the sizes are incorrect, the pin holder and ring holder can be changed, see maintenance of S15 gun on page 14-15.

4. Insert the brazing pin into the pin holder. The rounded tip should be facing away from the gun.

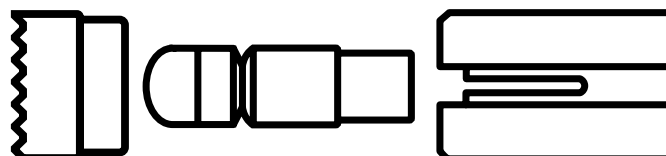

5. Insert the ceramic ring into the ring holder. The serrated edge should be facing away from the gun.

6. Press on/off button and select the right pin type by pressing the "setting" button. The unit will remember what setting was used last.

7. Hold the gun firmly with both hands as shown and pull the trigger just once. The electronic will by itself finish the brazing process.



8. Hold the gun in place for 3-4 sec after the brazing while the brazing cools down.

9. Remove the gun **straight** backwards without pulling the trigger!

10. After the braze has cooled, knock the shank off the brazing pin using a hammer.

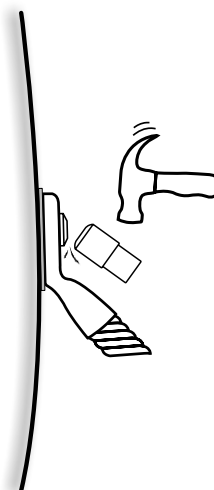

The brazing is completed.

NOTE:

If the brazing is aborted too early "ERROR" will turn on. The brazing should be redone for a good result. The error lamp will turn off after 8 seconds. Use a new ceramic ring for each new brazing.

IMPORTANT

The battery indicator "LOW BATT" flashes when the batteries are almost discharged. When the "LOW BATT" is constantly lit the batteries are discharged and no more brazings can be done. Charge the battery.

ERROR INDICATIONS ON THE UNIT:

ERROR led is lit

- The temperature of the battery is over +55 °C.

Action: Wait until the light goes out, then the temperature dropped and it is possible to braze again.

ERROR led flashes

- The temperature of the battery is below +10 °C.

Action: Leave the unit on, the built-in heating element will heat up the battery. Wait until light goes out and the temperature has risen, and it is possible to braze.

ERROR and LOW BATTERY led flashes

- The temperature of the battery is below +10 °C and the battery is almost discharged.

Action: Charge the batteries.

ERROR Led is lit after a braze

- The pin brazing was not complete.

Action: The braze should be remade to achieve good results.
The Led turns off after 8 seconds.

ERROR Led glows

- Failure of a sensor in the unit.

Action: The unit should be sent for repair.

LOW BATTERY Led flashes

- Battery is almost discharged.

LOW BATTERY led is lit

- Battery are discharged.

Action: Charge the batteries.

Nothing happen when you press the buttons

- The electronics may have gotten stuck.

Action: Remove control 5A fuse for a short time, put it back again.

The brazing never stops

- The electronics may have gotten stuck.

Action: Remove the gun and the ground magnet from the rails and disconnect them from the unit as soon as possible.
Remove the control 5A fuse, check that nothing has been damaged before putting the fuse back.

EQUIPMENT

- Always make sure the batteries are fully charged.
- Check the cables from time to time for damage.
- Check the contact surface on the ground magnet to ensure a good connection.
- Make sure that the brazing pin with the ferrule passes easily in the gun, centered.

BRAZING PINS AND FERRULES

- Keep them dry.

RAILBONDS AND CABLE LUGS

- Keep them free from oxidation.
- Keep them free from contamination like: Grease, oil.
- Make sure that they are not damaged.

SETTING RIGHT LIFT HEIGHT

The S15 brazing gun self adjust to the same lift height every time.
See separate instructions (page 16-17) if adjustment for the gun is necessary.

PIN HOLDERS

Squeeze the fingers on the pin holder together each time you feel that the brazing pin goes in too easy when mounting them into the pin holder. This is important since all the current goes thru the pin holder to the brazing pin. If the fingers are too loose the pin holder will be damaged and must be replaced.

REPLACE THE FUSES:

Push and unscrew anti-clockwise to remove fuse holder.
Replace fuse and mount fuse holder.

NOTE!

Control: 5A fuse
Grinder: 15A fuse



NOTICE

In addition to the Safetrack Precautions in this manual,
observe the following for equipment protection and care.

- Check that the pin holder is not burnt and holds the pin tightly. If not, remove the ring holder, clean all the parts and squeeze the fingers of the pin holder together.
- Check the cables on the gun from time to time for damage. Replace as required.
- Check that the lift level is correct with lift the level tool.
- Always store the tool in a clean dry space, safe from damage or pilferage.
- Always keep critical equipment markings, such as warning stickers and tags legible.
- Equipment repair should be performed by experienced personnel only.
- Do not use the equipment for applications for which it was not intended.

SPECIAL FUNCTIONS

1. BATTERY INDICATOR

Press and hold the “SETTING” button, and then push the “ON/OFF” button. “LOW BATTERY” LED will light. Release the buttons.

The LEDs on the front panel show the charge status of battery.



2. LIFT HEIGHT CONTROL

First follow step 1 above.

Press “SETTING” and the lights start flashing, at this point, you can check the lifting height of the gun.

3. PRESS “SETTING” one more time and you go back to battery indicator.

PIN & RING HOLDER OPTIONS

Part No.

For brazing pin

With Ring Holder

9211 (A)

8-9,5 mm

9202 for 8-9,5 mm pins



9213 (B)

M8 threaded

9204 for M8, M10 and M12 pins



9215 (C)

M10 threaded



9217 (D)

M12 threaded



PERIODICAL MAINTENANCE ON S15 AUTOMATIC GUN

1. Check that all cables and lugs are without damages and properly tighten in gun and unit.
2. Check that the right pin holder is fitted in the gun.

Make sure the pin holder is tight on the gun, otherwise a spark can destroy the axle.

Use a wrench to hold the nut from turning and tighten the pin holder as shown in the picture.

Do not allow the main shaft to turn, only turn the pin holder to tighten.

Use one 8 mm and one 10 mm wrench for 8-9,5 mm and M8 pin holders.

Two 10 mm wrenches for M10 and M12 pin holders.

The pin holder must also have a tight grip on the brazing pin, otherwise you can have a contact fault or a spark can arise and destroy the pin holder. To get a tighter fit, push the pin holder flares closer together with your fingers.



IMPORTANT

Make sure, never twist the axle when mounting the pin holder!

3. Check that the ringholder is the right type. You can remove it by hand and its ease of removing can be adjusted with the small screw on the side of the gun (see photo).

4. Load the gun with the appropriate pin & ferrule. Check that the axle moves easily with the pin and ferrule installed by pushing back and forward on the pin with your finger (see photo).

If the pin does not move easily, change either pin holder or ring holder. If it still does not move easily the axle is damaged and must be sent for repair.



CHECKING LIFT HEIGHT

Lift level tool: SAFE 91245

IMPORTANT

The normal lift height is 2 mm. This is very important for the arc and energy amount. Too high lift height increase the risk of a “cold brazing”, too low lift height reduce the time and increase misfires.



1. On the PinBrazing unit Econect, press and hold “SETTING” and press “ON/OFF”. When “LOW BATTERY” is lit, release buttons. Press “SETTING” and the leds will start to blink. In this mode it is able to check the lift height.

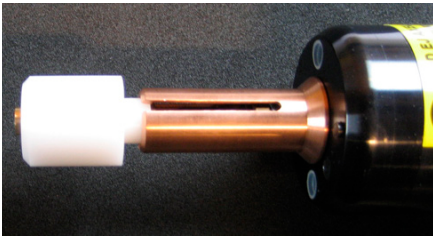

2. Insert the brass part of the tool in the pin holder and fit the plastic part in to the ring holder.

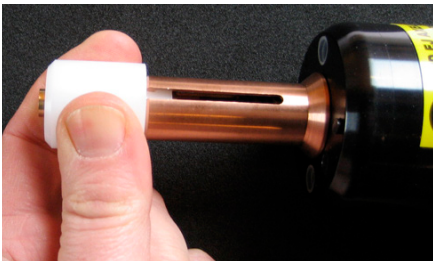

3. Press the trigger on the gun and watch the brass rod.

IMPORTANT!

Press the tool completely against the gun when triggering the gun. Otherwise the gun may be damaged!

IMPORTANT!

Hold the gun so the tool is horizontal.



4. The lift level is calibrated when the brass rod is in same level as the outer plastic sleeve.

Tolerance $\pm 0,2$ mm.

If the brass rod stick out more than 0,2 mm, then the gun needs to be calibrated, see point 4 on the next page.

If the brass rod goes in more than 0,2 mm, then the gun needs to be calibrated, see point 5 on the next page.

See next page (17) for instructions on how to calibrate the PinBrazing gun S15.

**Calibrate lift height on a S15 gun.
Only calibrate if the gun is maladjusted.**

1. On the PinBrazing unit Econect, press and hold "SETTING" and press "ON/OFF".
When "LOW BATTERY" is lit, release buttons.
Press "SETTING" and the leds will start to blink.
In this mode it is able to check the lift height.

2. Insert the brass part of the tool in the pin holder and fit the plastic part in to the ring holder.
See instruction point 2 on page 16.

3. Take off the plastic plug with the needle in the upper small hole in the front of the gun.

IMPORTANT!

Never adjust in the hole where the big plug is!

4. When lift height is **too low**:
Use the 3 mm hexagon allen wrench and adjust the screw in the small hole **counter-clockwise** about 1/4 of a turn then check with the lift level tool as in page 16.

5. When lift height is **too high**:
Use the 3 mm hexagon allen wrench and adjust the screw in the small hole **clockwise** about 1/4 of a turn then check with the lift level tool as in page 16.

If all is ok, fit the plug in the hole again.

If not ok, send for repair.



ACCESSORIES AND SPARE PARTS

PART	PART NUMBER
S15 Brazing gun	91015
S15 Angle brazing gun	910151
Pin holder A 8-9,5 mm	9211
Pin holder B M8	9213
Pin holder C M10	9215
Pin holder D M12	9217
Ring holder 8-9,5 mm	9202
Ring holder M8/M10/M12	9204
Extended Pin/Ring holder set, 8-9,5 mm	9227
Extended Pin/Ring holder set, M8	9229
Gun cable 2,7 m	9230-S15
Gun cable extension 5 m	9235-S15
Gun tool set	91250
Battery charger, stationary use, 36V 7A	8048
Battery charger, car use 12V/36V 2A	80561
Ground Switchable magnet 2,7 m	80730
Switchable magnet (no cable)	9035
Ground grip 2,7 m	8071
Cordless Grinding machine	593070
Grinding Pin/Stone	8025
Carbide burr, Type C	8014
Carbide burr, Type C Extended	8014XL
Fuse holder	91197
Fuse 200mAT (on circuit board)	91180
Fuse 1AT	91182
Fuse 15AT	91181
Accessories case	95240
Carrying harness	9523
Protective eyewear	8043

For more information, please visit www.safetrack.se.



Heavy Duty Case

Inside fits the following (*not included*):

- Grinding Machine
- Grounding Device
- PinBrazing Gun including cable
- Protective Eyewear
- Carrying Harness
- 2 tins (for Brazing pins & Ferrules)

Dimensions: 459x319x160 mm

Weight: 3,4 kg

Part no: 95240



Insulation Bag for Econect

Increased capacity in even colder weather.

Part no: 937005



Grinding Machine 18V

- Long-nose type
- Round collet nut reduces risk of damage on workpiece
- Restart function with warning light
- Rubber protection for heat insulation and grip

Technical information:

- Maximum wheel size 38 mm
- Speed (rpm) 25 000
- Incl. 2x 18V Li-Ion battery, 220V charger and case.

Dimensions: 402x82x118 mm

Weight: 2,0 kg (5.61 kg for the cpl. package)

Part no: 593070



Carbide burr Type C

Tungsten carbide, double diamond cut burr.

Suitable for Steel, Hardened Steel, Stainless Steel, Cast Iron, Titanium, Nickel, Copper / Copper Alloys.

Dimensions: 6 mm shank, 12 mm head diameter, 25 mm head length, 70 mm overall length.

Part no: 8014



Grounding Grip

Ground non-magnetic materials such as manganese rails, pipes or avoid grinding the ground spot and save some battery capacity.

Weight: 1,7 kg

Part no: 8071



Grounding Device 300A

Switchable ground magnet complete w. cable and connectors.

Length: 2,7m

Weight: 1,22 kg

Part no: 80730



SL87 / SL88 Extended PinBrazing Gun

Patented PinBrazing gun with the ability to extend up to 8 meters. It is made for connecting cathodic protection cables in drilled holes or holes made with vacuum excavation (Hydrovac). PinBrazing in holes as small as 10" (25cm) and up to 26"/8m deep.

- Requires unit Econect or S30 X/C
- Includes camera for easy operation
- Self adjusting lift height (patent)
- Grounding included in gun
- Weight: 19kg
- **Part no. 91061** (for S30 X/C)
- **Part no. 91062** (for Econect)

Add wire brusher 8007040 (220V)/8007045 (110V) with special bracket 8007048 and extension rods 9106115.



Back Carrying Harness

Carry the Econect unit on your back. Complete with Holster.

Weight: 3,5 kg

Part no: 93690

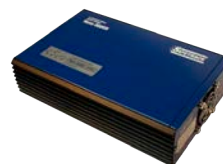

Charger for Econect

Stationary charger for Econect. 36V/230V

Weight: 2 kg

Part no: 8048



Car Charger for Econect

Charge Econect through the cars 12V outlet.

Weight: 1 kg

Part no: 80561

Cable lug Kit

Includes 100 pcs of each
 Brazing pin/Ceramic ferrule/Cable lug
 (Cable lugs are made specifically for PinBrazing)



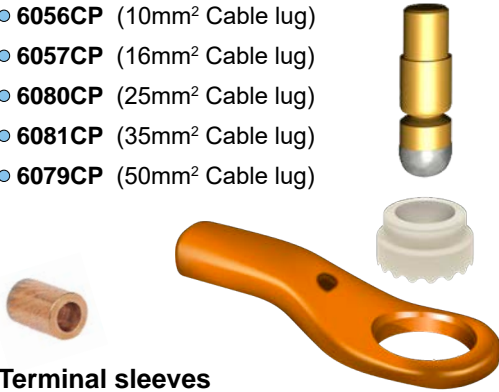





- **6056CP** (10mm² Cable lug)
- **6057CP** (16mm² Cable lug)
- **6080CP** (25mm² Cable lug)
- **6081CP** (35mm² Cable lug)
- **6079CP** (50mm² Cable lug)



Terminal sleeves

- **6700** (2,5mm² use with 6056CP)
- **6701** (4,0mm² use with 6056CP)
- **6702** (6,0mm² use with 6056CP)

Brazing pins & Ceramic ferrules

- **10051** (8mm) 
 - **10301** (8mm X) 
 - **10191** (9,5mm) 
 - **10381** (M8) 
 - **10401** (M10) 
 - **10421** (M12) 
-  ● **2003**
-  ● **2009**
-  ● **2012**

SnakeBite®



SnakeBite® - Patented PinBrazing connection for connecting anode leads without cable lugs. Just bend the wire to a round shape with the enclosed special plier and pinbrazed directly to the pipe.

- Connect anodes directly to pipe
 - Safe for internal coatings
 - No need for cable lugs
 - No need for crimping tools
 - No dangerous explosive material
- **1090CP**
 (kit of 100 Brazing pins & Ceramic ferrules incl. pliers)

Scan the QR Code for more
 PinBrazing material

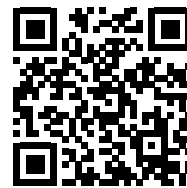

RETURNING EQUIPMENT FOR REPAIR

To best help you, we ask you to contact us before returning your product.

We understand the need for promptly handling repairs. You can greatly help us process, repair & return your equipment speedily by providing us clear and detailed information about the problems with your equipment.

Please always include your full company contact details in/with the parcel.

If, in our opinion, a repair is not economic we will contact you to discuss your options. Please tell us if you require a cost estimate before we start working on your unit.

If you decide not to go ahead with the repair after receiving our estimate nor purchase a replacement, we will make a standard administration charge +freight to cover the inspection and cost of returning the products to you.

Repair or replace?

When considering whether to repair or replace we would suggest you consider the following:

- a) The cost of a new replacement?
- b) Do current models have new features or options which you would find useful?
- c) The warranty period of a replacement vs the repair limited warranty?
- b) Your cost to return the product for repair? Sending parcels can be surprisingly expensive.
- c) The cost of the product repair?
- d) The processing & return delivery cost?

What if my product fails shortly after the warranty expires?

Fortunately this does not happen often but is difficult for both of us when it does. The official answer is that a warranty is for a specific period, having said that we do not wish to be unreasonable. If you have a product which fails just outside of warranty please contact us to discuss your case, we may be able help you.

Safetrack Support

support@safetrack.se
+46 40 44 53 03

IMPORTANT

Return of used/faulty Econect units.

We insist that you do **not** return used/faulty Econect units with the battery still inside.
Please contact us for instructions on how to remove the battery.



SAFETRACK BAAVHAMMAR AB

Möllebergavägen 339-24, 245 93 Staffanstorp, Sweden

Phone. +46 (0)40 44 53 00

sales@safetrack.se www.safetrack.se

DECLARATION OF CONFORMITY

according to EN ISO 17050-1:2010

Manufacturers name: **SAFETRACK BAAVHAMMAR AB**Manufacturers address: **SAFETRACK BAAVHAMMAR AB
Möllebergavägen 339-24
245 93 STAFFANSTORP
SWEDEN**Product: **Pinbrazing / SafeBond® unit**
Model number: **ECONECT (X15)*****The object of the declaration described above is in conformity with the relevant Union harmonisation legislation:***Electromagnetic Compatibility Directive (EMC) 2014/30/EU,
Restriction of Hazardous Substances (RoHS) 2011/65/EU.***References to the relevant harmonised standard used or referenced to the other technical specifications in relation to which conformity is declared.***EMC: EN 60974-10:2014
EN 55011(1998):A1:1999 A2:2002
EN 61000-4-2(1995)
EN 61000-4-3 (2002)

RoHS: EN 50581:2012

The products have been tested in a typical configuration.

Staffanstorp, Sweden 2021-11-01**Torsten Båvhammar**
PresidentIn case of a modification of the products which has not been agreed on with us,
this declaration becomes null and void and the warranty expires.

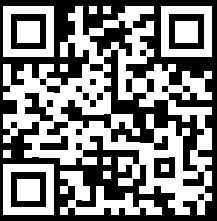

**SCAN THE QR CODE
TO DOWNLOAD OR READ THIS
MANUAL ONLINE**

